



# Samsung Solid-State Disk

BREAKTHROUGH FLASH STORAGE DEVICE



Samsung designed the SSD to look like a hard drive from the outside. Inside, it includes NAND flash memory, controller, connectors and other elements on a printed circuit board.

## High-Performance, Low-Power Storage Device for Mobile PCs is Light, Rugged and Reliable

Samsung's Solid-State Disk (SSD) is an advanced NAND flash-based replacement for traditional hard disk drives, leveraging the company's longtime leadership in memory technology. This next-generation solution offers several advantages over rotating magnetic media such as significantly lower power consumption, remarkable ruggedness, high reliability, less weight and outstanding performance.

The SSD system includes NAND flash memory, controller, connectors and other elements on a printed circuit board and can fully replace hard drives in notebook, sub-notebook and tablet PCs. Its weight is approximately half that of a conventional hard drive, thus further increasing easy system portability. The device also uses less power — about .5W in operational mode and less than 0.01W in standby mode. In a typical use scenario combining read/write, seek and standby, the SSD requires roughly one-tenth the power of a hard drive. This gives users more than 30 minutes of additional use before a battery charge is needed.

Solid-State Disk Block Diagram

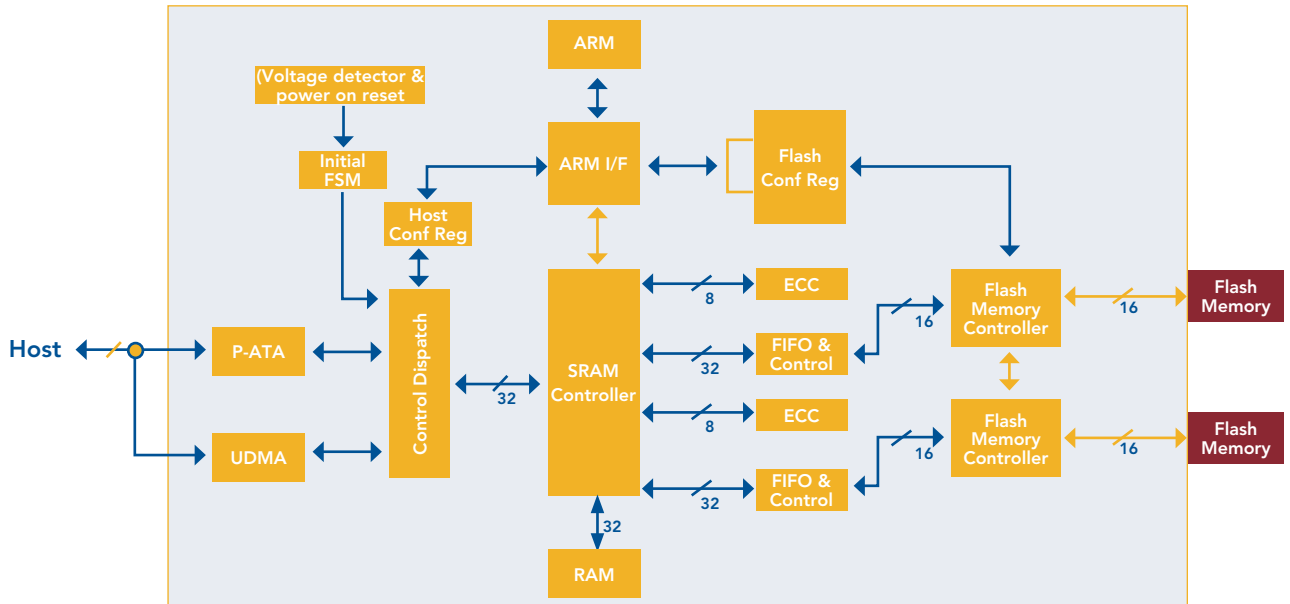



SAMSUNG



Samsung's SSD is available 2.5-inch and 1.8-inch form factors with storage capacities ranging from 4 to 32 gigabytes.

### Excellent Read/Write and Boot-up Performance

The performance of Samsung's SSD exceeds that of a similarly sized hard drive by more than 150%. For example, it can read data at a rate of 57MB per second and achieves write speeds of 32MB per second, which is more than twice as fast as comparable hard disk drives. Its speed lets PC users cut boot-up time in half when compared to a conventional 1.8-inch hard drive.

As a non-volatile storage device, the SSD has no moving parts such as the motor, disks and heads of a hard drive. Thus it eliminates spin-up time, seek time and rotational latency while delivering sustained high-speed data transfers. The SSD is also extremely friendly to its surroundings. Its lack of moving parts makes it noise free and its ultra-low power consumption virtually eliminates heat emissions.

The SSD is also highly rugged, standing up to shock and vibration damage while performing in extreme temperatures from -20 to 80 degrees Celsius. These performance features make it well suited to a broad range of environments, including those in the demanding military and industrial areas.

### Fully Compatible with Mobile PCs

Samsung designed the SSD to look like a hard disk drive from the outside. The host interface is fully compliant with the ATA5 specification and supports PIO modes 0-4 and UDMA mode 4 (Ultra DMA 66MHz). The SSD is available in 2.5-inch and 1.8-inch form factors with storage capacities ranging from 4 to 32 gigabytes.

### Key Features & Benefits

#### Reduced Power Requirements

- No moving parts
- Super-low operating and standby power needs
- Extends battery life up to 10%

#### Fast Performance

- No spin up
- No seek time
- No rotational latency
- Sustained high-speed data transfers
- 57MB/s read, 32MB/s write speeds
- Can cut boot-up time in half

#### Reliable

- No moving parts to fail
- Greater resistance to shock & vibration
- Operates in extreme temperatures (-20° to 80°C)

#### Improved Operation

- Noise free
- Virtually no heat emissions
- Less than half the weight of conventional hard drive



Samsung Semiconductor, Inc.

3655 North First St., San Jose, CA 95134-1713  
TEL: 408-544-4000 FAX: 408-544-4950  
www.usa.samsungsemi.com

© 2006. Samsung is a registered trademark of Samsung Electronics Co. Ltd. All other names and brands may be claimed as the property of others. Microsoft® and Windows® are registered trademarks of Microsoft Corporation.

DS-06-STOR-001 Printed 5/06